

# RV

## 70 SUPERLOTUS - ACCESSORI ACCESSORI

RISCALDANTE VANO



ITALIAN CULINARY ART

Le immagini presentate non sono vincolanti.  
La ditta si riserva di apportare modifiche senza  
preavviso.

# RV

## 70 SUPERLOTUS - ACCESSORI ACCESSORI

RV

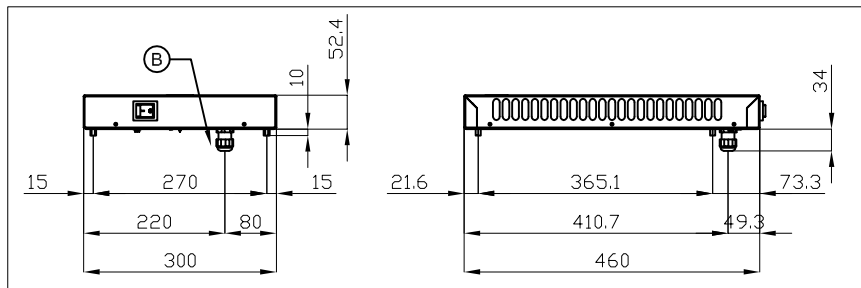

RRV

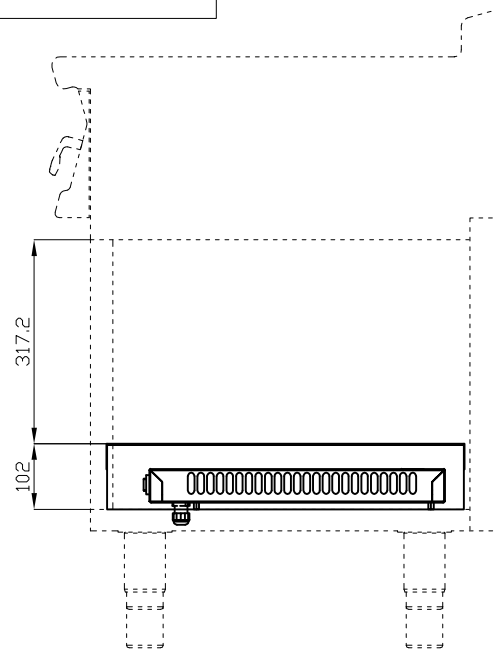
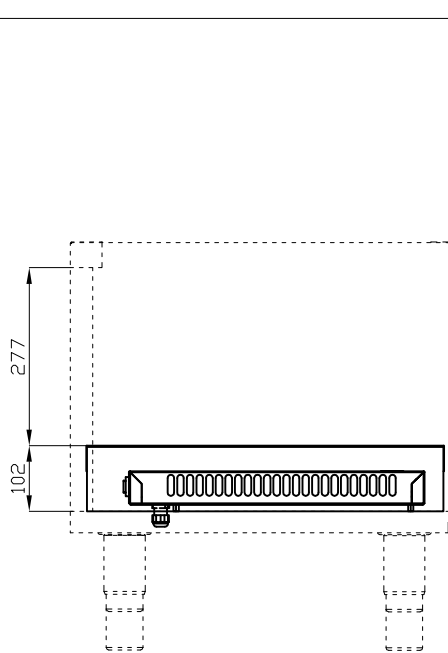
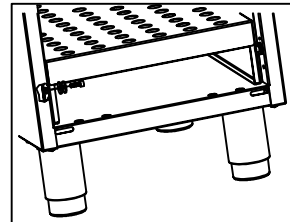

A	Targhetta caratteristiche		B	Allacciamento elettrico	
---	---------------------------	--	---	-------------------------	--

MODELLO: RV  
 DIMENSIONI: cm. 32x 48,5x 8h  
 POTENZA ELETTRICA: 0,75 kW  
 VOLTAGGIO: 230V~  
 FREQUENZA: 50/60 Hz

kg: 8  
 m<sup>3</sup>: 0.083  
 mm: 48x62x28



BUY LOTUS BUY ITALY

Le immagini presentate non sono vincolanti.  
 La ditta si riserva di apportare modifiche senza  
 preavviso.



LOTUS S.P.A. Via Calmaor, 46  
 31020 San Vendemiano(TV) - Italy  
 Tel. + 39 0438 778020 / 778468  
 Fax + 39 0438 778277  
 www.lotuscookers.it - lotus@lotuscookers.it