

# FPG-20

## FRYERS

### CONFECTIONER'S GAS FRYERS - TOP

Gas confectioner's fryer - 20 liters Tank cm.  
50x38x24h - 1 basket cm. 47x35x8h Sieve  
and lid for tank

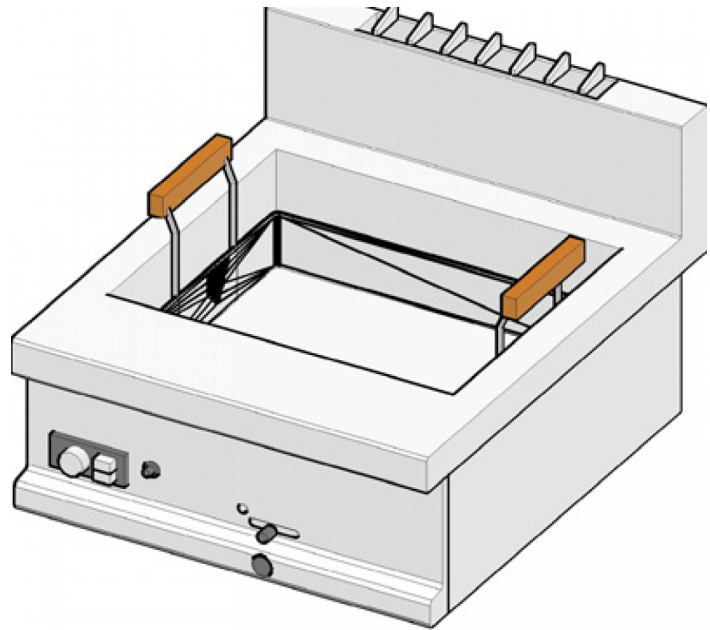

Construction - Fabricated using CrNi 18/10 AISI 304 grade Stainless Steel Scotch-Brite Satin polish Finish, incorporating 1 mm thick worktop, rounded edges, chromed details and rear splash back. Model - Professional Confectioner's Gas Fryer. Tank with optimum width and depth for frying sweets, include basket and lids, tank filter with basket support. Burners with Piezoelectric ignition and pilot light, thermostatic and thermocouple safety valves. Front oil drain. Maintenance - All serviceable parts are accessible by the easy removal of front control panel. Fittings - Appliance is supplied with both LPG and Natural Gas conversion jets and adjustable feet.



ITALIAN CULINARY ART

The pictures are purely representative. The manufacturer reserves the right to modify the technical data and models without previous notice.

# FPG-20

FRYERS

CONFECTIONER'S GAS FRYERS - TOP

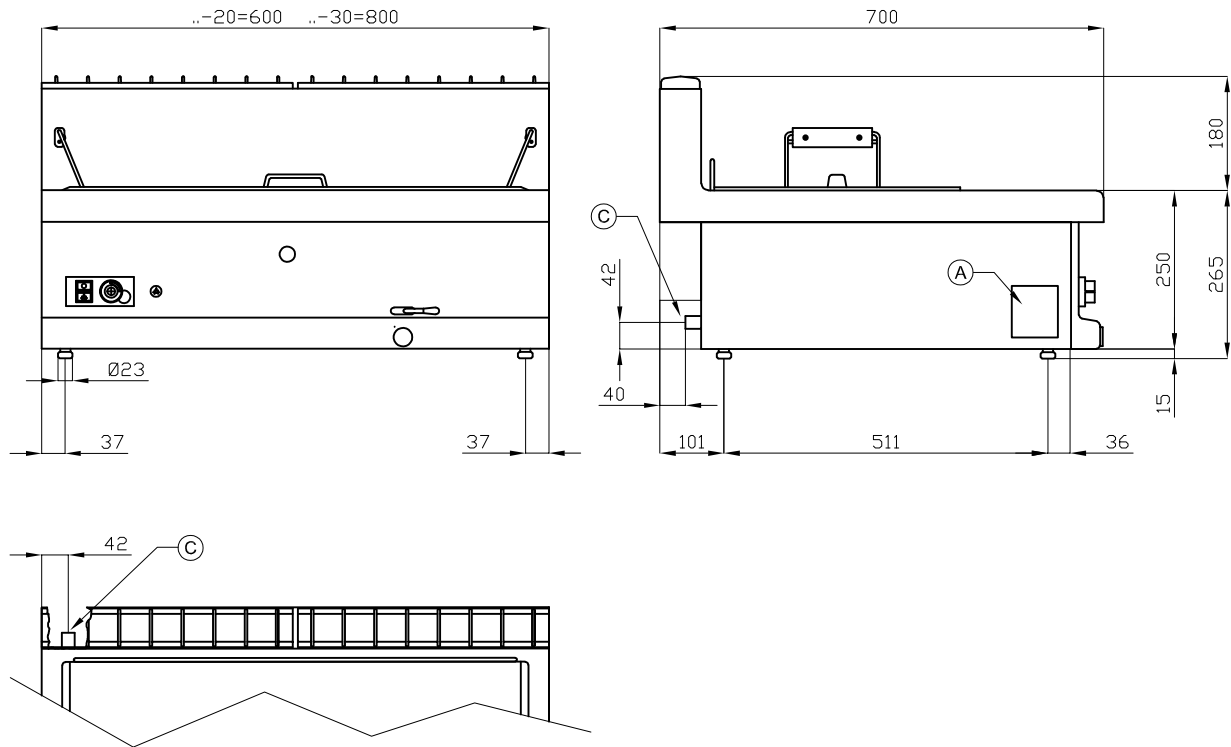

A	Data plate	C	Gas connection	ISO 7-1 1/2" M
---	------------	---	----------------	----------------

MODEL: FPG-20  
 DIMENSIONS: cm. 60x 70x 25h  
 GAS POWER: 11,2 kW / 9.630 kcal/h  
 GAS TYPE: Natural Gas / LPG



kg: 43  
 m<sup>3</sup>: 0.306  
 mm: 630x770x630

BUY LOTUS BUY ITALY

The pictures are purely representative. The manufacturer reserves the right to modify the technical data and models without previous notice.



LOTUS S.P.A. Via Calmaor, 46  
 31020 San Vendemiano(TV) - Italy  
 Tel. + 39 0438 778020 / 778468  
 Fax + 39 0438 778277  
 www.lotuscookers.it - lotus@lotuscookers.it