

FMPE-25

FRYERS

CONFECTIONER'S ELECTRIC FRYERS

Confectioner's cabinet fryer threephase - 24 liters - Tank cm. 70x42,5x17,5h 1 basket cm. 67x35x8h - Sieve and lid for tank - Drip tray with sieve

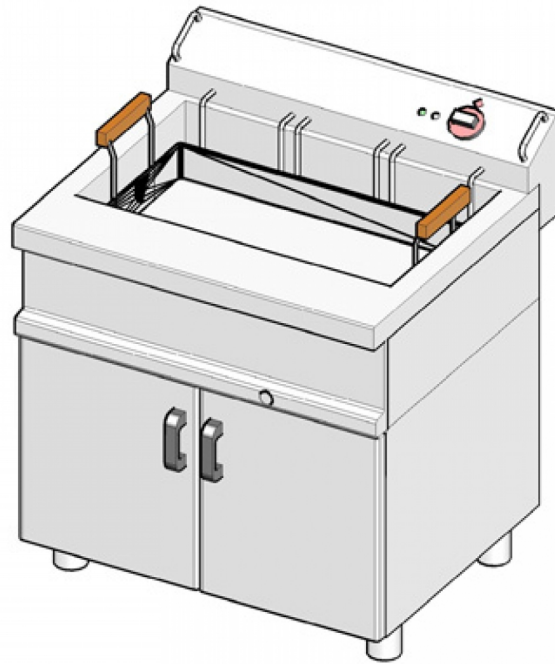

Construction - Fabricated using CrNi 18/10 AISI 304 grade Stainless Steel Scotch-Brite Satin polish Finish, incorporating 1 mm thick worktop, rounded edges, chromed details and rear splash back. Model - Professional Confectioner's Electric Fryer. Tank with optimum width and depth for frying sweets, include basket and lids, sheathed elements and lift-up basket rest. Double Thermostat for operating and over heat safety. Maintenance - Resistance box easy to be removed for a total cleaning. Fittings - Appliance is supplied with adjustable feet. Oil filter drain pan included.



ITALIAN CULINARY ART

The pictures are purely representative. The manufacturer reserves the right to modify the technical data and models without previous notice.

FMPE-25

FRYERS

CONFECTIONER'S ELECTRIC FRYERS

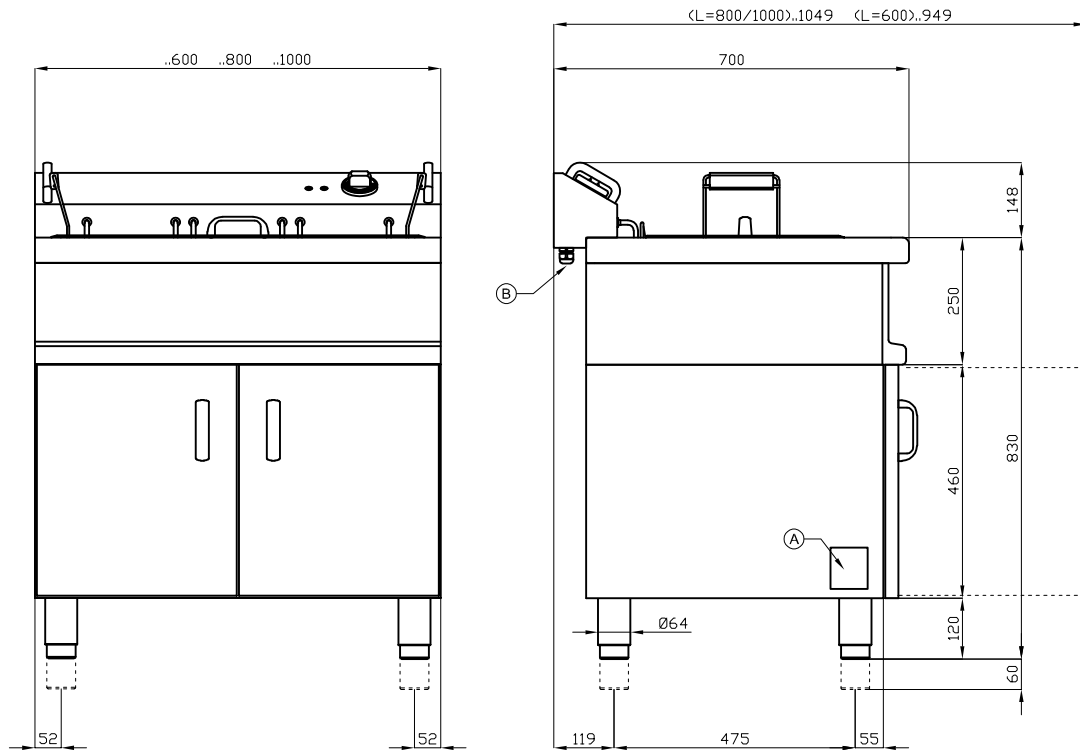

A	Data plate	B	Electrical connection
---	------------	---	-----------------------

MODEL: FMPE-25
DIMENSIONS: cm. 80x 70x 85h
ELECTRIC POWER: 10,2 kW
VOLTAGE: 400V~3N
FREQUENCY: 50/60 Hz



kg: 72
m³: 0.78
mm: 830x770x1220

BUY LOTUS BUY ITALY

The pictures are purely representative. The manufacturer reserves the right to modify the technical data and models without previous notice.



LOTUS S.P.A. Via Calmaor, 46
31020 San Vendemiano(TV) - Italy
Tel. + 39 0438 778020 / 778468
Fax + 39 0438 778277
www.lotuscookers.it - lotus@lotuscookers.it