

# FE-2/8

FRYERS

ELECTRIC FRYERS - TOP

Fryer lts. 8+8 threephase - 2 tanks cm.  
22x32,5x20h - 2 baskets cm. 20x27x11h -  
Production 18 kg/hr



Construction - Fabricated using CrNi 18/10 AISI 304 grade Stainless Steel Scotch-Brite Satin polish Finish, incorporating 1 mm thick worktop, rounded edges, chromed details and rear splash back. Model - Professional Electric Fryer. With single or Double tank to include both basket and lids, sheathed elements and lift-up basket rest. Double Thermostat for operating and over heat safety. Front oil drain. Maintenance - Resistance box easy to be removed for a total cleaning. Fittings - Appliance is supplied with adjustable feet.



ITALIAN CULINARY ART

The pictures are purely representative. The manufacturer reserves the right to modify the technical data and models without previous notice.

# FE-2/8

FRYERS

ELECTRIC FRYERS - TOP

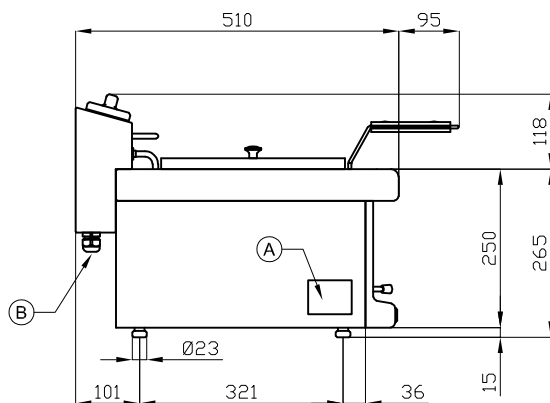
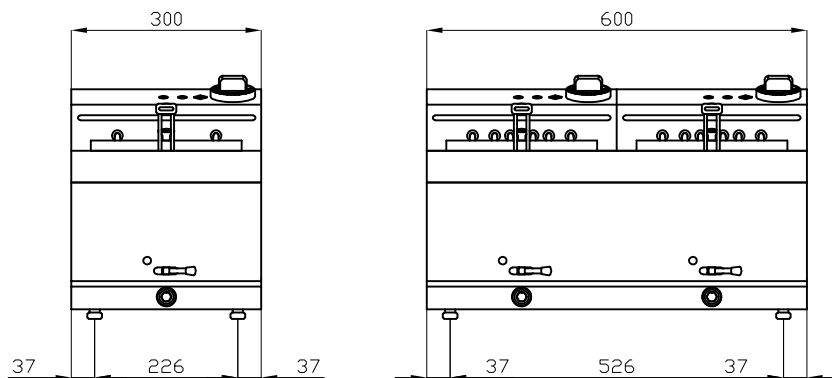

A	Data plate	B	Electrical connection
---	------------	---	-----------------------

MODEL: FE-2/8  
DIMENSIONS: cm. 60x 51x 25h  
ELECTRIC POWER: 10,8 kW  
VOLTAGE: 400V~3N / 230V~3  
FREQUENCY: 50/60 Hz

kg: 27  
m<sup>3</sup>: 0.161  
mm: 630x580x440



BUY LOTUS BUY ITALY

The pictures are purely representative. The manufacturer reserves the right to modify the technical data and models without previous notice.



LOTUS S.P.A. Via Calmaor, 46  
31020 San Vendemiano(TV) - Italy  
Tel. + 39 0438 778020 / 778468  
Fax + 39 0438 778277  
www.lotuscookers.it - lotus@lotuscookers.it