

# CPAD-84ET

ELECTRIC FREELOTUS

ELECTRIC PASTA COOKERS 80

Pasta cooker threephase 40 lts. Tank cm.  
30,7x50,9x32,7h. Automatic Water loading  
with level sensor - overflow device and floor  
draining (BASKETS EXCLUDED)



Construction - Fabricated using CrNi 18/10 AISI 304 grade Stainless Steel Scotch-Brite Satin polish Finish, incorporating 2 mm thick worktop, chromed details. Tank fabricated in AISI 316. Model - Professional Electric Pasta Cookers, possible automatic water loading and with level sensor. Single tanks incorporating built in water fill tap, overflow safety valve and floor drain. Perforated pasta baskets with safety handles, available in different sizes for multiple product cooking. High performance tubular heating elements, safety thermostat and 4-position switch control. Maintenance - Tank cleaning facilitated by rotating coils. Fittings - Fixing system.



ITALIAN CULINARY ART

The pictures are purely representative. The manufacturer reserves the right to modify the technical data and models without previous notice.

# CPAD-84ET

ELECTRIC FREELOTUS

ELECTRIC PASTA COOKERS 80

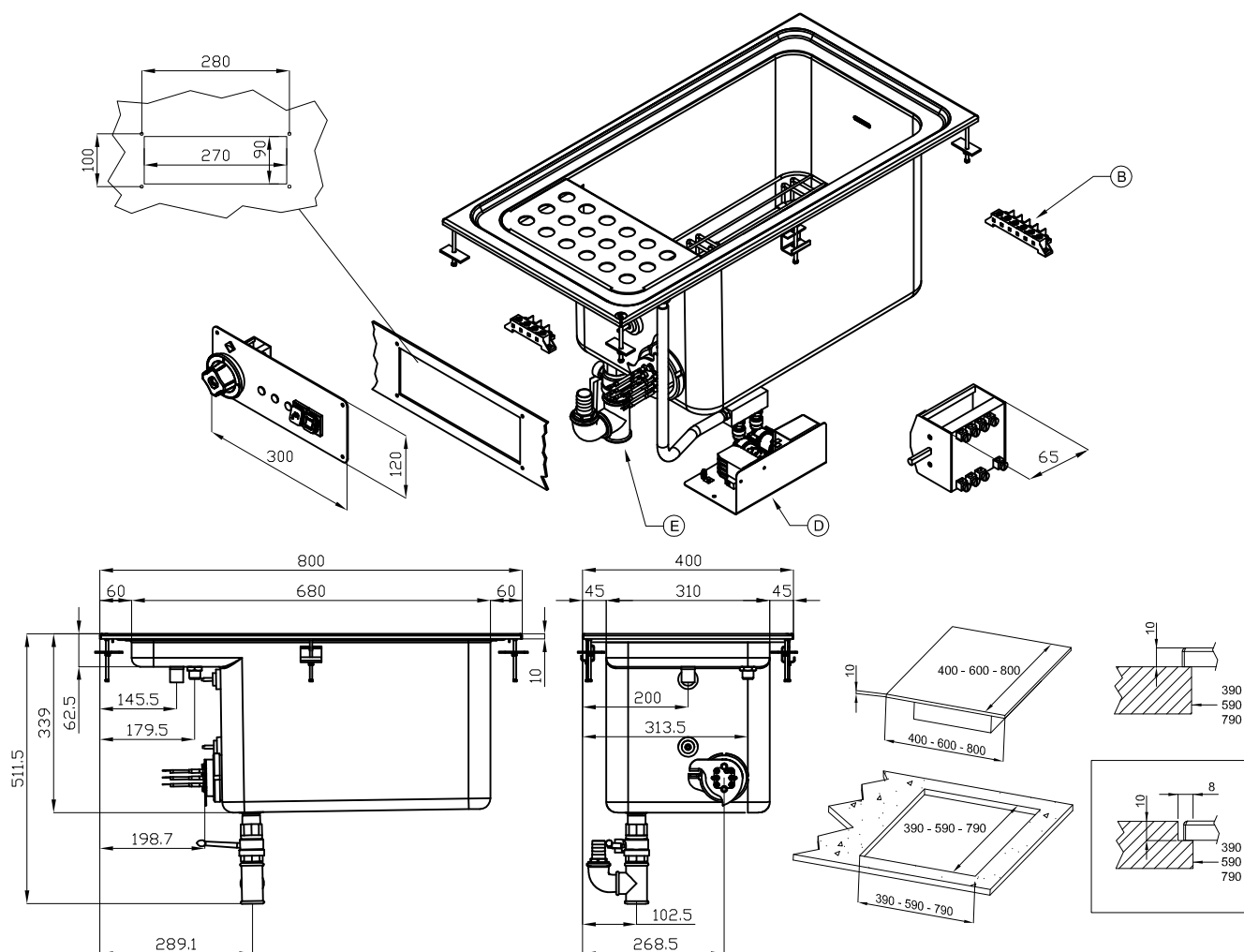

A	Data plate		B	Electrical connection	
D	Cold water connection	ISO 7-1 1/2" F	E	Water drainage	ISO 7-1 1" F

MODEL: CPAD-84ET  
 DIMENSIONS: cm. 40x 80x 51h  
 ELECTRIC POWER: 13,5 kW  
 VOLTAGE: 400V~3N  
 FREQUENCY: 50/60 Hz



kg: 30  
 m<sup>3</sup>: 0.263  
 mm: 430x970x630

BUY LOTUS BUY ITALY

The pictures are purely representative. The manufacturer reserves the right to modify the technical data and models without previous notice.



LOTUS S.P.A. Via Calmaor, 46  
 31020 San Vendemiano(TV) - Italy  
 Tel. + 39 0438 778020 / 778468  
 Fax + 39 0438 778277  
 www.lotuscookers.it - lotus@lotuscookers.it