

CPA-66ET

60 MAGICLOTUS

ELECTRIC PASTA COOKERS



Pasta cooker threephase 40 lts. - Tank cm.
51x30,7x32,7h. - Automatic Water loading
with level sensor - overflow device and floor
draining (BASKETS EXCLUDED)



Construction - Fabricated using CrNi 18/10 AISI 304 grade Stainless Steel Scotch-Brite Satin polish Finish, incorporating 1mm thick worktop, rounded edges, chrome details and rear splash back. Tank fabricated in AISI 316. Knobs with waterproof grades IPX5. Model - Professional Electric Pasta Cooker, possible automatic water loading and with level sensor. Single tank incorporating built in water fill tap, overfill safety valve and floor drain. Perforated pasta baskets with safety handles, available in different sizes for multiple product cooking. High performance tubular heating elements, safety thermostat and 4-position switch control. Maintenance - All serviceable parts are accessible by the easy removal of front control panel. Tank cleaning facilitated by rotating coils. Fittings - Appliance is supplied with adjustable feet.



ITALIAN CULINARY ART

The pictures are purely representative. The manufacturer reserves the right to modify the technical data and models without previous notice.

CPA-66ET

60 MAGICLOTUS
ELECTRIC PASTA COOKERS



View 3D

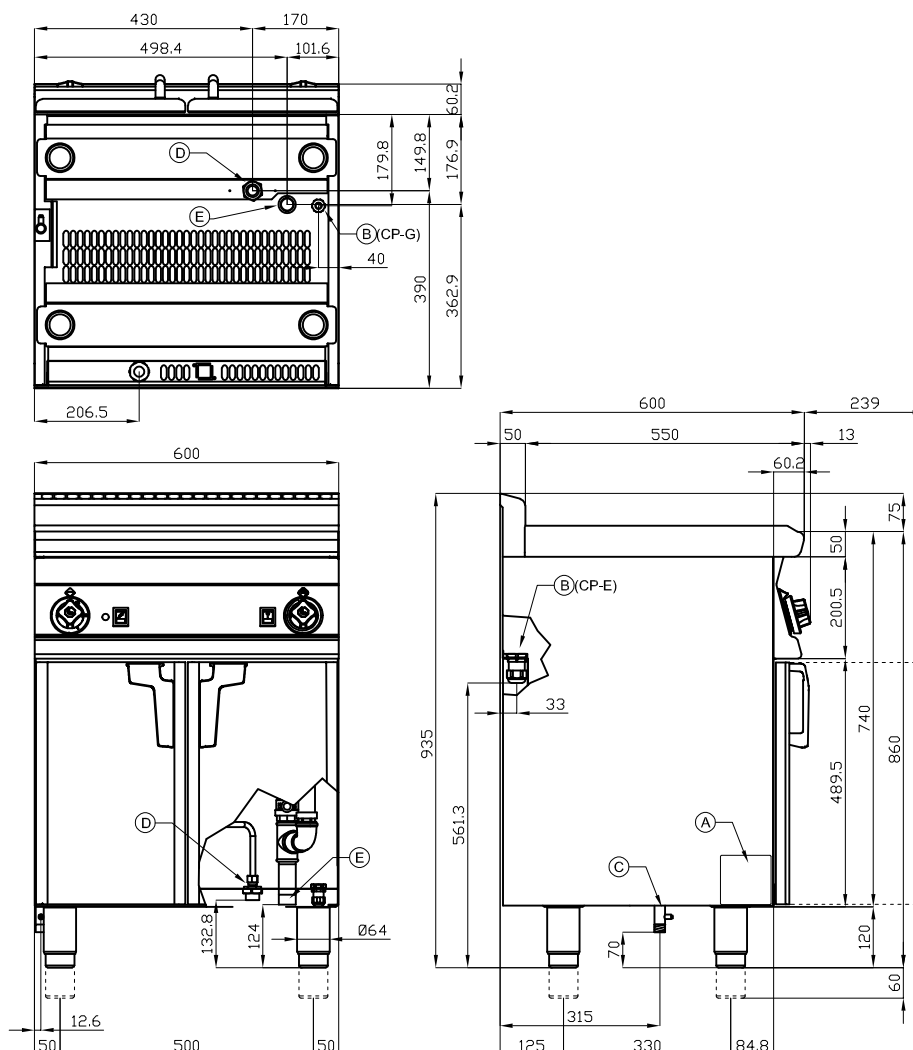

A	Data plate		B	Electrical connection	
D	Cold water connection	ISO 7-1 3/4" M	E	Water drainage	ISO 7-1 1" M

MODEL: CPA-66ET
DIMENSIONS: cm. 60x 60x 90h
ELECTRIC POWER: 13,5 kW
VOLTAGE: 400V~3N
FREQUENCY: 50/60 Hz

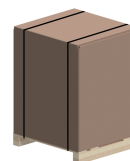

kg: 82
m³: 0.469
mm: 630x670x1110

BUY LOTUS BUY ITALY

The pictures are purely representative. The manufacturer reserves the right to modify the technical data and models without previous notice.



LOTUS S.P.A. Via Calmaor, 46
31020 San Vendemiano(TV) - Italy
Tel. + 39 0438 778020 / 778468
Fax + 39 0438 778277
www.lotuscookers.it - lotus@lotuscookers.it