

CP-4ET

65 MAGICPROF ELECTRIC PASTA COOKERS

Pasta cooker threephase 17 lts. Tank cm. 31x33,5x20h. N. 2 baskets cm. 15x29x15h - Water loading electro-valve Drain-cock + overflow device



Construction - Fabricated using CrNi 18/10 AISI 304 grade Stainless Steel Scotch-Brite Satin polish Finish, incorporating 1mm thick worktop, rounded edges, chrome details and rear splash back. Tank fabricated in AISI 316. Model - Professional Electric Pasta Cooker with single tank incorporating built in. Perforated pasta baskets with safety handles, for multiple product cooking. Water load electrovalve, overfill safety valve and back water drainage tap. High performance tubular heating elements, safety thermostat and 4-position switch control. Maintenance - All serviceable parts are accessible by the easy removal of front control panel. Tank cleaning facilitated by rotating coils. Fittings - Appliance is supplied with adjustable feet.



ITALIAN CULINARY ART

The pictures are purely representative. The manufacturer reserves the right to modify the technical data and models without previous notice.

CP-4ET

65 MAGICPROF ELECTRIC PASTA COOKERS

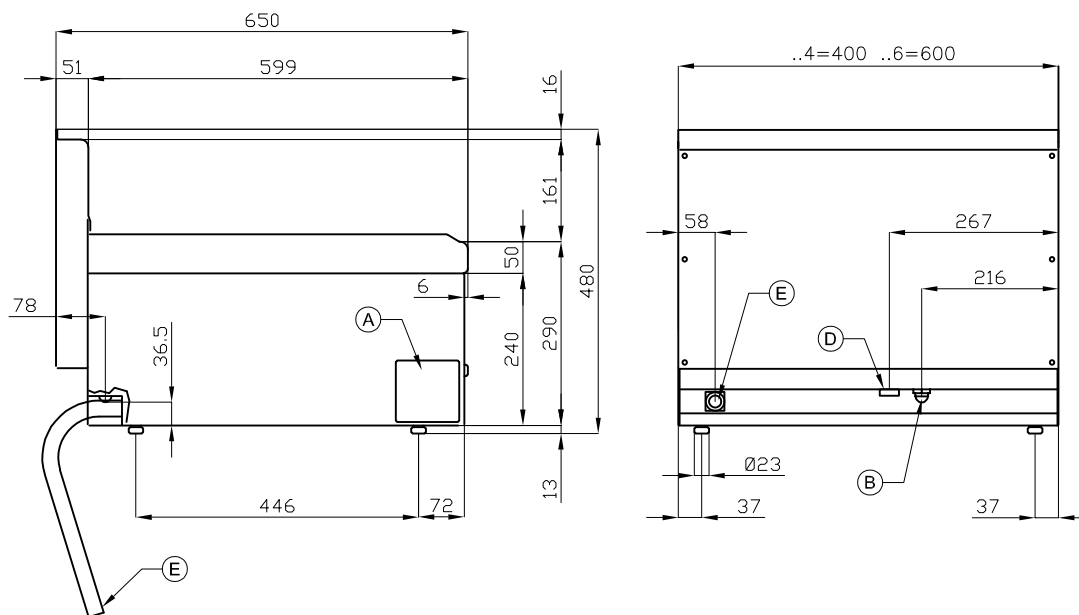

A	Data plate		B	Electrical connection	
D	Cold water connection	ISO 7-1 3/4" M	E	Water drainage	GOMMA Ø27e-19imm L=1300mm

MODEL: CP-4ET
DIMENSIONS: cm. 40x 65x 29h
ELECTRIC POWER: 4 kW
VOLTAGE: 400V~2N / 230V~3 / 230V~
FREQUENCY: 50/60 Hz



kg: 27
m³: 0.181
mm: 430x690x610

BUY LOTUS BUY ITALY

The pictures are purely representative. The manufacturer reserves the right to modify the technical data and models without previous notice.



LOTUS S.P.A. Via Calmaor, 46
 31020 San Vendemiano(TV) - Italy
 Tel. + 39 0438 778020 / 778468
 Fax + 39 0438 778277
 www.lotuscookers.it - lotus@lotuscookers.it