

Installation and operating instructions

GAS PASTA COOKER FOR PROFESSIONAL USE

CP-558G CPA-558G CP-116G CPA116G

Model LIBR.ISTR.CP110G

Code 5630516A0

Review 1

Edition date 08/06/2022

Language English

LOTUS S.p.A.

Via Calmaor, 46

31020 San Vendemiano

+39 0438 778020

+39 0438 778277

Contents

1	INTRODUCTION	3
1.1	Installation drawing	3
1.2	Components	5
1.3	Example installation of the appliance	8
2	GENERAL INFORMATION	9
2.1	Declaration of compliance	9
2.2	User information, RAEE Directive on waste electrical and electronic equipment	10
2.3	Technical data table	10
3	INSTALLATION	11
3.1	Delivery checks	11
3.2	Removing the packaging	11
3.3	Mechanical installation	11
3.4	Electrical/gas connections	11
3.5	Water connection and drainage	14
4	BURNERS TECHNICAL DATA TABLE (ITGB)	15
4.1	Burners technical data table	15
6	INSTRUCTIONS FOR USE	16
6.1	General information	16
6.2	Switching the pilot burner on	16
6.3	Starting the main burner and adjusting the temperature	17
6.4	Switching the main burner off	17
6.5	Switching the appliance off	17
6.6	Emptying the tank	17
6.7	Pasta cooker with automatic loading	17
6.8	Characteristics of the feed water	18
7	MAINTENANCE	19
7.1	Routine	19
7.2	Replacing the main burner nozzle	19
7.3	Replacing the pilot burner nozzle	19
7.4	Minimum setting	20
7.5	Spare parts	20
8	CLEANING	21
8.1	Routine cleaning	21

1 INTRODUCTION

1.1 Installation drawing

FIG. 1 CP-558G, CPA-558G

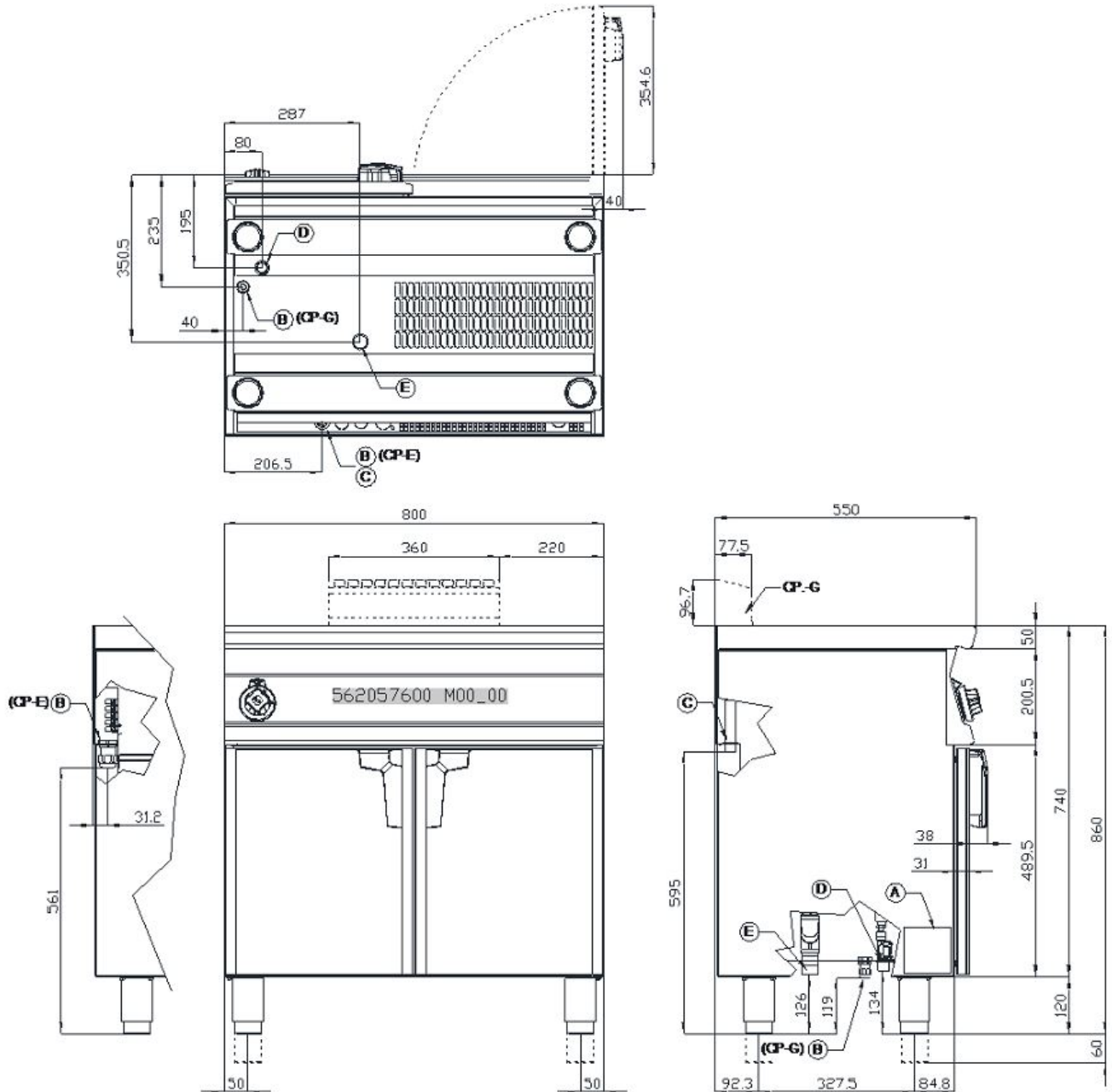

- A Data Plate
- B Electrical connection
- C Gas connection
- D Water connection R 3/4" M
- E Water drain R 1" M

FIG. 2 CP-116G, CPA116G

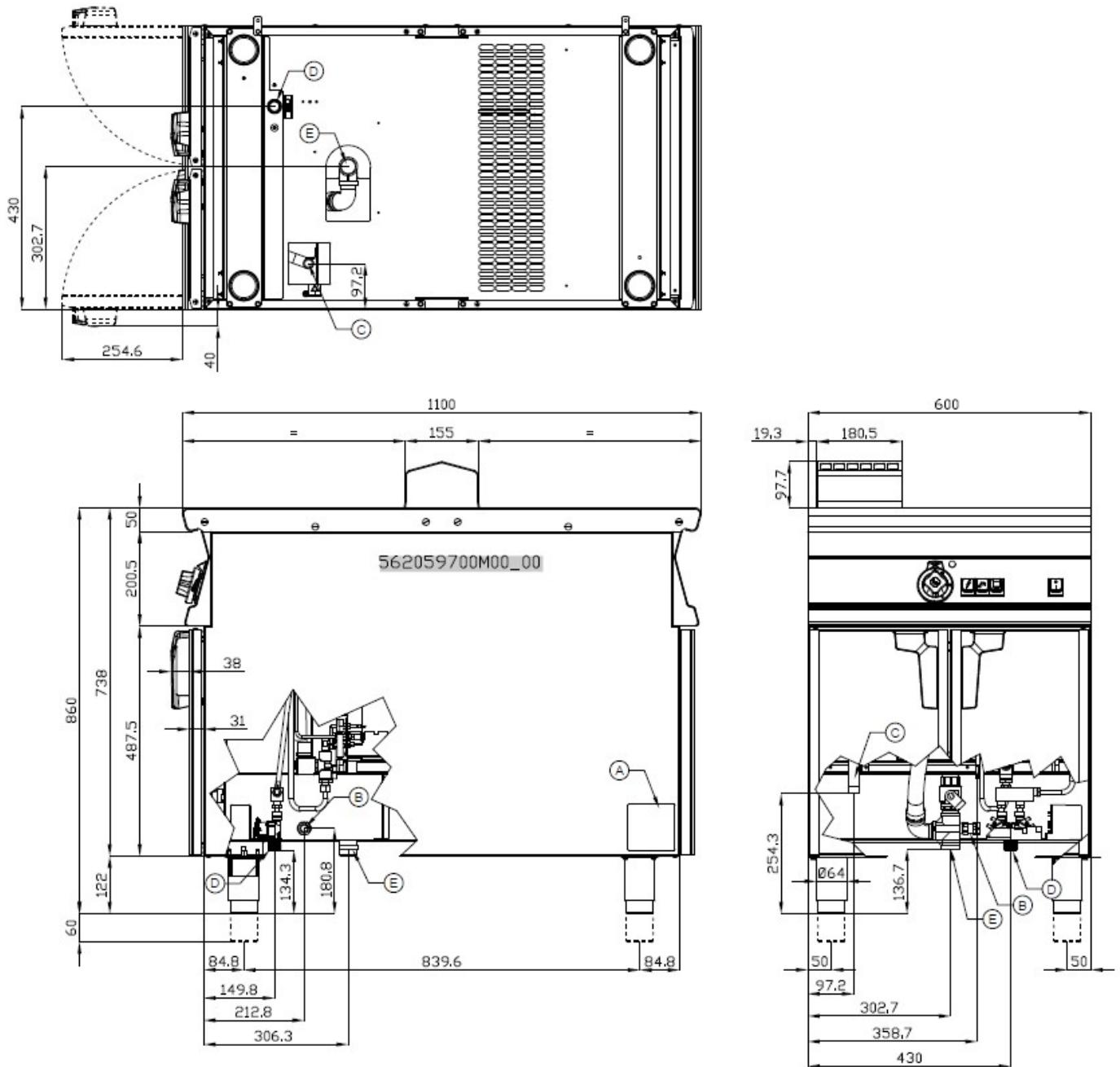

- A Data Plate
- B Electrical connection
- C Gas connection
- D Water connection **R 3/4" M**
- E Water drain **R 1" M**

1.2 Components

FIG. C

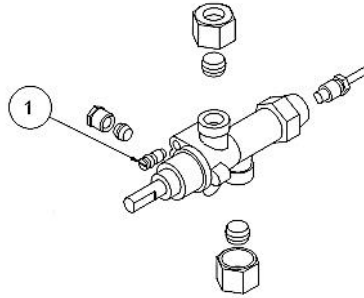

1 By-pass

FIG. B CP...

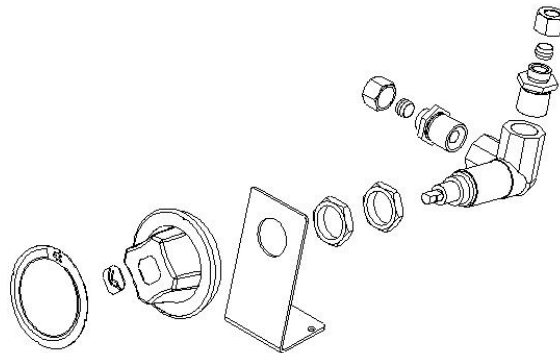

Water filling tap

FIG.D

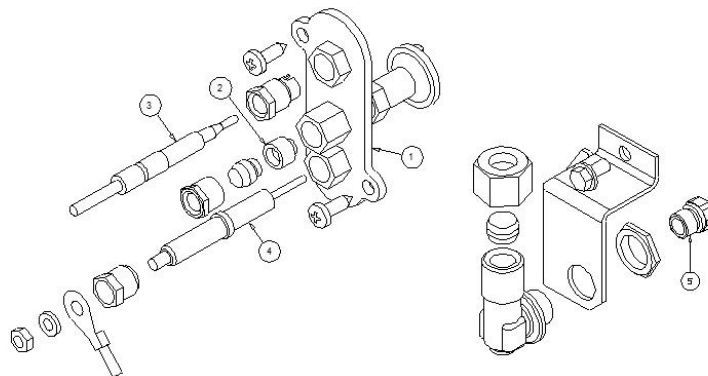

- 1 Bracket
- 2 Pilot light nozzle
- 3 Ignition spark plug
- 4 Extends drainage
- 5 Injector

WIRING DIAGRAM CP-558G, CP-116G

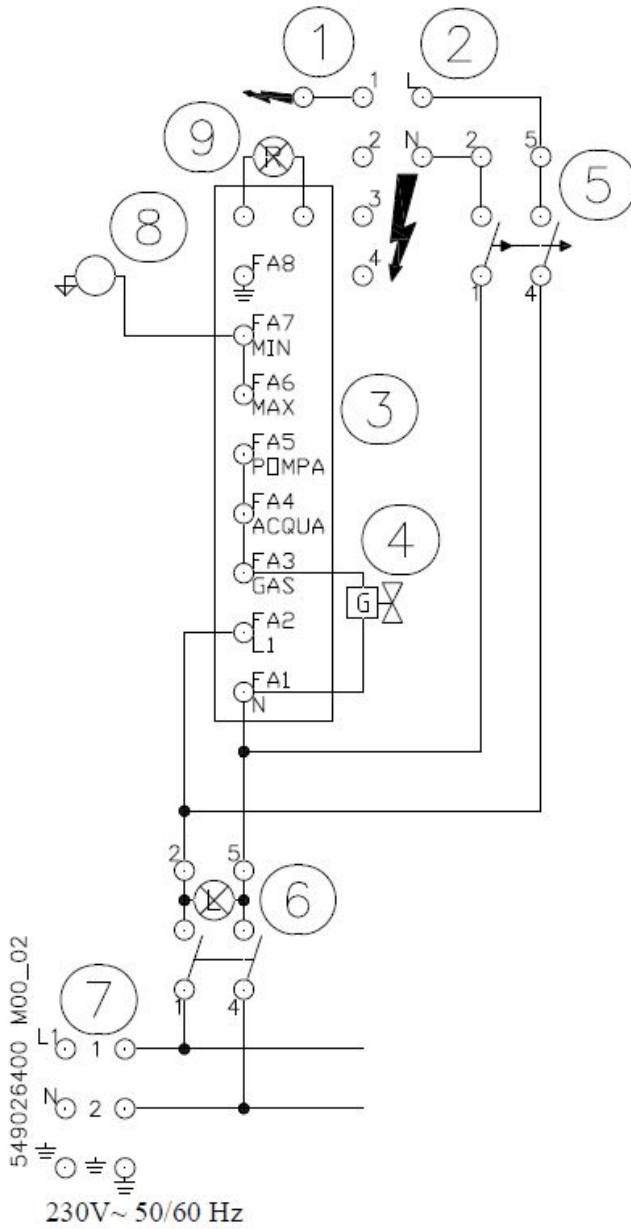

- 1 Ignition spark plug
- 2 Burner ignition control unit
- 3 Water level control unit
- 4 Gas solenoid
- 5 Power button
- 6 Bipolar switch
- 7 Power supply terminal board
- 8 Level probe
- 9 Red warning light

1.3 Example installation of the appliance

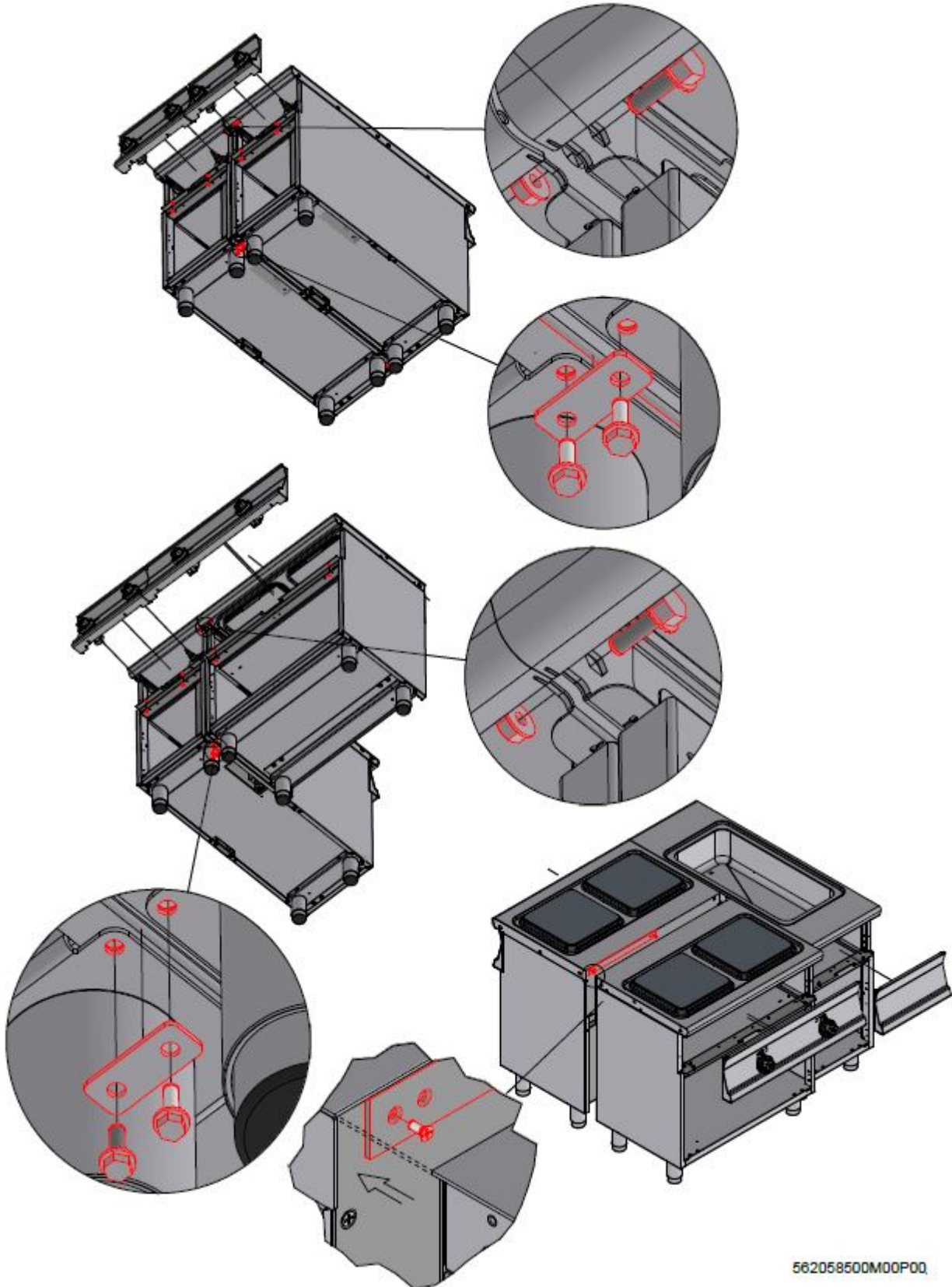

2 GENERAL INFORMATION

2.1 Declaration of compliance

The manufacturer declares that the appliances comply with the requirements of the regulation GAR 2016/426 for the gas part and directive 2014/30/EU, 2014/35/EU for the electrical part. Installation must be performed in compliance with current regulations, especially with regard to ventilation of the premises and the exhaust gas evacuation system.

- Read the warnings in this manual carefully. They provide important information about safe installation, use and maintenance.
- The instruction manual must be kept for the entire duration of the equipment and made available to users for every possible consultation. The manual should be consulted for any information concerning installation, use and maintenance of the appliance.
- After removing the packaging, check the integrity of the equipment.
- All packaging materials (plastic bags, polystyrene, staples, etc.) must be disposed of in compliance with current regulations.
- Before connecting the appliance, make sure that the information on the data plate matches the electricity and gas mains where the appliance is installed. **The manufacturer accepts no liability if the equipment is not connected in accordance with current regulations.**
- Always keep all parts of the equipment clean to avoid the risk of oxidation/rust and/or aggression by chemical agents.
- The equipment must only be used by personnel trained for the purpose.
- **The installation must be implemented by professionally qualified personnel in accordance with the manufacturer's instructions and current reference standards.**
- The electrical safety of this equipment is only ensured when it is correctly connected to an effective ground/earth system as required by current electrical safety standards. The manufacturer cannot be held liable for any damage caused if the system is not connected to ground/earth.
- Before carrying out any cleaning or maintenance tasks on the equipment, unplug it from the electricity mains. In the event of faults or malfunctions, always deactivate the appliance.
- **Repair work of any kind must only be performed by qualified personnel.**
- This appliance must only be used for its expressly intended purpose for cooking or heating food. Any other use is considered improper.
- The appliance is intended for professional use and must be used by trained personnel.
- The installation and possible transformation to another power supply voltage (if envisaged), or transformation for operation with another type of gas, must be implemented exclusively by qualified and authorised professional personnel.
- Before using the appliance, carefully clean all surfaces intended to come into contact with food.
- The manufacturer declines any and all liability for any direct or indirect damage resulting from improper use of the equipment. The manufacturer declines any and all liability for damage caused by incorrect installation, tampering, poor maintenance and unskilled use. Moreover, the manufacturer declines any liability for possible inaccuracies that may be contained in this booklet attributable to errors in transcription or printing and equally reserves the right to make any changes to the product it deems useful and/or necessary without compromising its essential characteristics.
- **The manufacturer cannot be held liable for any damage caused by failure to comply with these basic standards and all other use and maintenance standards contained in this booklet.**

2.2 User information, RAEE Directive on waste electrical and electronic equipment

With regard to the regulatory framework of reference of the European Community, we remind the user of the following:

- Used AAE (Electrical and Electronic Equipment) products must be collected separately
- The user can carry out this collection in the RAEE collection systems and return the equipment to the distributor when purchasing a new one
- Plus being RoHS compatible, (in accordance with Directive 2011/65/EU on the restriction of the use of certain hazardous substances in electrical and electronic equipment) the potential effects on the environment and human health may be due to the misuse of the same equipment or parts of it
- The symbol  next to the rating plate indicates the obligation of separate collection
- The penalties provided for in the event of improper disposal of RAEE (Waste Electrical and Electronic Equipment) are those provided for by the national transpositions of European Directives 2012/19/EU

2.3 Technical data table

Electrical technical data table CP S110G

MODEL	POWER SUPPLY	MAXIMUM ABSORPTION (A)	MAXIMUM ELECTRIC POWER (kW)	POWER SUPPLY CABLE silicon type
CP-558G	230V~ 50/60 Hz	0,1	0,02	3 x 1 mm ²
CPA-558G	230V~ 50/60 Hz	0,16	0,035	3 x 1 mm ²
CP-116G	230V~ 50/60 Hz	0,1	0,02	3 x 1 mm ²
CPA-116G	230V~ 50/60 Hz	0,16	0,035	3 x 1 mm ²

Technical data table CP S110G

MODEL	DIMENSIONS	GAS FITTING ISO 7-1	WATER INLET	WATER OUTLET	RATED TOTAL GAS FLOW (kW)
CP-558G	80x55x90h	R 1/2GM	R 3/4"M	R 1"M	13,95
CPA-558G	80x55x90h	R 1/2GM	R 3/4"M	R 1"M	13,95
CP-116G	60x110x90h	R 1/2GM	R 3/4"M	R 1"M	13,95
CPA-116G	60x110x90h	R 1/2GM	R 3/4"M	R 1"M	13,95

3 INSTALLATION

3.1 Delivery checks

On delivery, it is important to check the following:

- External conditions of the packaging
- The general status of the equipment
- The conformity of the model with the information in the technical data plate and the instruction manual
- The conformity of the equipment and components to the order form

3.2 Removing the packaging

While removing the packaging, take care not to damage the appliance. Remove the protective film from the stainless steel and eliminate any traces of glue. Do not smoke. Perform this operation away from sources of heat and wear protective gloves. Do not disperse packaging material in the environment, keep it out of the reach of children and dispose in compliance with current legislation.

3.3 Mechanical installation

Place the appliance on a flat base. Adjust and stabilise the appliance by acting on the support feet. Make sure that the surrounding walls and/or equipment are capable of withstanding the heat emitted by this appliance. Connect the water supply (if necessary).



Caution

Do not install the appliance near equipment/machines used in cold processes. If the appliance has to be installed close to cold process equipment, it is advisable to install non-combustible thermal insulating material and/or neutral elements between them.

3.4 Electrical/gas connections

Before being offered for sale on the market, the appliance was subjected to gas and electrical testing (as required). The appliance is supplied without a power cable. The installation technician must connect the equipment in compliance with current safety regulations on the basis of the power of the appliance.



Note

The ID plate is located in the compartment inside the door for appliances with compartments, or on the left side for appliances with an oven or a top. A second plate with the model and serial number is located inside the dashboard and a third is included with the certificate of conformity. The serial number can also be tracked from the sales document (after 2008). The plate has all the data needed for correct electrical installation. The installation and possible conversion to another power supply voltage (if envisaged) must be implemented exclusively by professionally qualified and authorized personnel. Before using the appliance, carefully clean all surfaces intended to come into contact with food.

Warning

Installation operations, any conversion to other types of gas and start-up must only be performed by qualified personnel, in accordance with current regulations.

Gas systems, electrical connections and premises where the appliances are installed must comply with current regulations in the country of installation; in particular, the appliance must be installed in a room with good ventilation, if possible under a suction hood to ensure complete evacuation of the exhaust gases formed during combustion. The air required for combustion is 2 m³/h per kW of installed power. The appliance can be installed alone or in series with other appliances in our production range. A minimum distance of 10 cm between appliances must be respected to prevent contact with any walls made of flammable material; furthermore, appropriate measures should also be adopted to ensure the thermal insulation of flammable parts, such as the installation of heat shields; take special care to ensure that appliances are installed in an appropriate and safe manner. The support feet can be adjustable in height and any unevenness can therefore be eliminated.

ELECTRICAL CONNECTION

Caution

For direct connection to the grid, a device must be provided to ensure disconnection from the grid, with a contact opening distance that allows complete disconnection under overvoltage category III conditions, in accordance with the installation rules

The connection terminal is located behind the rear wall. Proceed as follows to install the power supply cable:

- Remove the rear panel.
- Pass the new connection cable through the cable gland, connect the leads to the corresponding terminal on the terminal block and fasten them securely.
- Lock the cable with the cable gland and refit the panel. The earth/ground lead must be longer than the others so that if the cable gland breaks it is disconnected after the power cables.

Note

Make sure that the mains voltage complies with the data on the appliance's ID plate and that there is good conductivity to earth/ground. Pay attention when inserting leads to ensure they do not obstruct the normal course of work and routine appliance cleaning operations. Also make sure that the power cable is never pulled taut and is not placed in contact with sources of heat.

Note

The connection cable must have the following characteristics: it must be silicone type (to withstand temperatures of 180 °C), and must have an appropriate cross-section for the power of the appliance (see technical data table).

EQUIPOTENTIAL

The appliance must be connected to an equipotential system. The connecting screw is located on the rear of the appliance and is marked by the yellow symbol above it.

Warning

The manufacturer is not liable for and does not indemnify damages caused by incorrect inadequate installations that do not comply with these instructions.

GAS CONNECTION

The gas connection (see installation drawing) must be implemented using steel or copper pipes or steel hoses, in compliance with applicable national standards. All appliances must be equipped with a gas shut-off

valve and fast-closing valve. Once installation is complete, make sure that there are no gas leaks from the fittings; to do this, do not use a naked flame but substances that do not cause corrosion, such as solutions of soapy water or leak detectors. All our appliances are subjected to detailed examination: the type of gas, pressure in use and the pertinent category are indicated on the data plate (see attachment).

**Note**

The year of construction of the appliance is indicated under "N" on the data plate. The first 2 digits indicate the year of construction.

• THERMAL OUTPUT CONTROL

The appliances must be checked in order to verify that their thermal output is correct:

- Thermal output is indicated on the appliance's data plate;
- Firstly, make sure that appliance is set for the type of gas used and then make sure that the indication on the data plate matches this gas. To adapt the appliance to another type of gas, make sure that the type of gas in question complies with the information in this instruction manual.

**Warning**

Pressure is measured with a pressure gauge (minimum resolution of 0.1 mbar) mounted on the appropriate socket. Remove the M6 locking screw and insert the pressure gauge tube. The test must be performed with all the burners on the appliance switched on and all the appliances in the same line switched on. After taking the measurement, replace the screw, firmly tighten and check the seal.

Liquid gas connection G30 / G31

The liquid gas connection pressure is 30 mbar for butane and 37 mbar for propane. Check the data plate, measure the pressure and verify that the description of the nozzle installed matches the information provided by the manufacturer.

Methane gas connection H G20

The methane gas connection pressure is 20 mbar. Check the data plate, measure the pressure and verify that the description of the nozzle installed matches the information provided by the manufacturer.

• CHECKING THE PRIMARY AIR FOR MAIN BURNERS AND PILOT NOZZLE

For burners equipped with air adjustment, set the adjustable bushing and lock it with a screw. The "Burner technical data" table shows approximate values for the "h" parameter (primary air). The primary air flow volume must be adjusted to avoid a flame cut-off when the burner is cold and a flame blowback when the burner is hot. The pilot air adjustment is set testing for the gas which the appliance will use. In the event of conversion to other types of gas, adjust the air using the adjustment bush until the pilot flame is steady and has an intense blue colour.

Disposition for conversion and installation for other types of gas:

Our appliances are tested and set for liquid gas or natural gas (see attached data plate). Conversion or adaptation to another type of gas must be performed by a specialist technician. The nozzles for the various types of gas are contained in a bag included in the supply and are marked in hundredths of mm (see "Burners" technical data table).

• INSTRUCTIONS FOR EVACUATING EXHAUST GASES

- "A1" type devices (see data plate)

"A" type appliances must discharge combustion products into appropriate hoods, or similar devices, connected to an efficient fume stack or directly to the outside. (Natural evacuation) Fig. 1

If this is not possible, using an air suction device connected directly to the outside is permitted (**Forced Evacuation**) Fig.2, having a flow capacity not lower than the value defined in point 4.3 of the UNI-CIG 8723 standard.

- In the case of forced evacuation

The gas supply to the appliance must be directly servo-controlled by the system and must stop if the flow rate drops below the values indicated in point 4.3 of the UNI-CIG 8723 standard. Resetting the gas supply to the appliance must be possible only by hand.

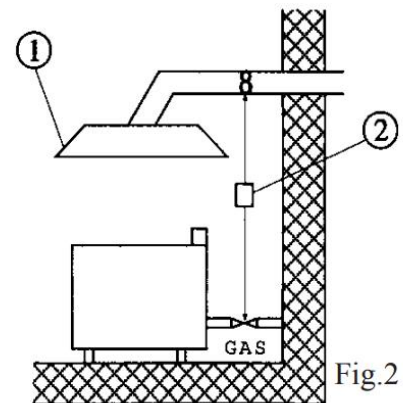
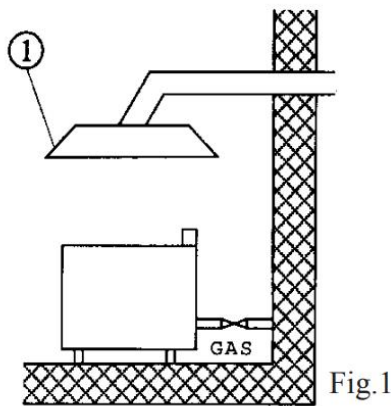

- 1 Extractor hood
- 2 Servo system

3.5 Water connection and drainage

- It is advisable to connect the appliance to the hot water pipe (max. 60 °C) to reduce heating times; we also recommend installing a shut-off valve up-line of the appliance
- The discharge pipe must be connected to a suitable drain in compliance with applicable legislation. It is advisable to connect pipes without bends to avoid bottlenecks or siphon effects. Water is drained by gravity. Inasmuch, it is essential that the drain is below the exit point of the pipe

Commissioning: before using the appliance, clean it carefully, especially the tank (see the "cleaning and care" section). Check the appliance's water connection and operate it in accordance with the instructions given below



Warning

The appliance must only be used under surveillance

Filling with water: make sure that the drain tap lever is in the closed position. Open the tap to fill the tank with water up to the level indicated by the lower notch.

4 BURNERS TECHNICAL DATA TABLE (ITGB)

4.1 Burners technical data table

Technical data table - Burner CP S110G

	12.68 kWh/KG G30 BUTANE 30 mbar	12.87 kWh/KG G31 PROPANE 37 mbar	9.45 kWh/m ³ st. G20 METHANE H 20 mbar
CP..-558G CP..-116G Burner 13.95 kW min. 4.8 kW			
Burner injector 1/100 mm	1 x 195	1 x 195	1 x 285
Minimum adjustment 1/100 mm	100	100	adjustable
Pilot injector	25	25	41
Consumption	kg/h 1.100	kg/h 1.083	m ³ st./h 1.481

6 INSTRUCTIONS FOR USE

6.1 General information

This appliance must only be used for its expressly intended purpose for cooking or heating food. Any other use is considered improper. The appliance is also intended for industrial use and **must only be used by personnel trained for use and aware of the risks that the hot element entails.**





Warning

The appliance operates at high temperatures, so the following is necessary:

- *Pay attention to the areas surrounding the hot surface during routine normal operation (danger of scalding);*
- ***RISK OF BURNS*** *Do not touch hot surfaces floor with your hands or other parts of the body to avoid burns caused by high temperatures;*
- *After switching off the appliance, wait for a sufficient time for it to cool before carrying out any cleaning or maintenance operation.*
- *Do not operate the appliance without water in the tank*

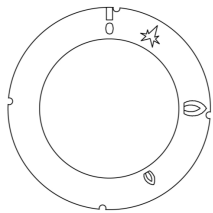
6.2 Switching the pilot burner on



The corresponding burner marked on the index is indicated above each knob on the front panel 

- When the appliance is powered up, the red indicator light flashes briefly for about 1/2 second
- If there is no water in the tank, the red indicator light continues flashing
- Open the water tap to fill the tank up to the level mark; filling must be higher than the minimum level sensor but not exceed the maximum level marked on the tank
- For models with automatic control water filling starts. The desired level can be selected by pressing the button with symbol ; high level for cooking pasta, low level for steaming



Note

If water does not reach the lower level sensor, the burner remains OFF



- Place gas knob in position ★ and hold it pressed. Simultaneously press the gas start button ⚡ : the pilot lights up



Note

The flame might go out, in which case the procedure must be repeated.

6.3 Starting the main burner and adjusting the temperature

- Turn the knob into position  to set the burner to maximum
- Turn the knob into position  to set the burner to minimum

6.4 Switching the main burner off

- Turn the knob into position . The burner turns OFF and only the pilot flame remains ON

6.5 Switching the appliance off

- Press and turn the gas cock knob to position "0". This control blocks the gas supply to both the main burner and the pilot burner

6.6 Emptying the tank

To perform this operation, open the drain tap (lever in vertical position) which can only be reached from the door of the cabinet underneath the appliance



Note

It is advisable to perform this operation using water that is not excessively hot

6.7 Pasta cooker with automatic loading

If the probe does not detect water in the tank, the system resets the correct level and after 15 sec. disables the heating element: an alarm is signalled by the red indicator light flashing. When the probe detects water again, the heating element is immediately activated and after 3 sec. automatic refilling is interrupted. The system monitors the filling phase through a TIME-OUT.

- **Slow refilling button**



When the "slow refilling button" is active, the system fills the tank slowly to prevent possible foaming

- **Level button**

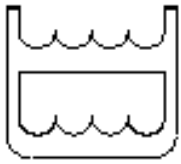

The "level button" defines the level of water in the tank: high level for cooking pasta, low level for steaming



Warning

Keep the level sensor clean



Caution

If the probe does not detect water in the tank for more than 15 sec., the system disables the heating element: an alarm is signalled by the red indicator light flashing. When the probe detect water again, the heating element is activated and the red indicator light switches OFF.

• **TIME-OUT**

Once the level probe is uncovered, the micro-controller activates an internal timer for the duration of this stage. If the filling lasts (continuously) for more than 350 seconds, the system blocks the operation of the device and an alarm is signalled by the red indicator light ON steady. To reset the alarm condition, first eliminate the fault that caused it to trip (broken or disconnected level probes, water system problems, drain tap open ...) **and then switch the system OFF/ON** .

6.8 Characteristics of the feed water

The inlet must be supplied with drinkable water having the specific characteristics listed below, **otherwise the warranty will be forfeited**

- **Total hardness** between 0.5 and 5 French degrees to reduce the formation of scale
- **Pressure** between 50 and 250 kPa (0.5-2.5 bar)
- **pH** above 7
- **Electrical conductivity** between 50 and 2000 $\mu\text{S}/\text{cm}$ (20 °C)
- **Chloride ion concentration (Cl-)** not too high (acceptable reference value: 10ppm) to avoid attacking the internal steel structures

7 MAINTENANCE

7.1 Routine

When using the appliance over time, it is essential to perform regular maintenance to ensure safe operation. We therefore recommend stipulating a service contract.



Caution

Maintenance must only be performed by specialist personnel in compliance with current regulations and our own instructions.

Before carrying out any maintenance and/or cleaning operation:

- Disconnect the appliance from the mains power supply and/or close the gas.
- Wait for a sufficient time for the appliance to cool down.
- Do not wash the appliance with direct or high-pressure jets of water, since any infiltration of water into the electrical components could jeopardise correct operation of the appliance and its safety systems.



Warning

For maintenance/replacement of components, order and use only original spare parts.

Replacing parts must exclusively be performed by authorised and/or qualified personnel. When replacing the electrical components of the machine and the electrical panels, scrupulously follow the technical characteristics for the replacement component indicated on the component itself. The appliance does not require any special maintenance but during the use of the equipment it is advisable to check the following at least once a year (possibly increasing the frequency depending on the degree of use):

- The status of connections especially on the terminal board and the power supply cable, as well as the status of the gas connections;
- The operating condition of the various components (perform a functional test);
- For appliances fitted with rotary resistances, remove the hub, grease it and replace the three o-ring seals to avoid possible leaks.

7.2 Replacing the main burner nozzle

- Remove the front screws fastening the dashboard/panel and pull it outwards
- Detach the starter cable
- Using a suitable wrench, unscrew the nozzle and replace it with an appropriate new one
- The main burner does not require any regulation of the primary air

7.3 Replacing the pilot burner nozzle

The pilot burner flame has a fixed air supply. The only necessary item is replacement of the nozzle depending on the type of gas used (see technical data table).

- Unscrew the coupling connecting the pilot tube to the pilot itself and slide out the nozzle to be replaced
- Replace the nozzle with the appropriate version and make sure that, after ignition, the flame correctly touches the tip of the thermocouple

**Warning**

After conversion to another type of gas, update the technical data plate to indicate the type of gas for which the appliance has been converted.

7.4 Minimum setting

- After conversion to use another type of gas, or if a flame is too high when the knob is in position  (small flame), adjust the minimum setting by turning the by-pass screw. For operation with LPG, the by-pass must be completely closed; for operation with natural gas, it must first be closed and then opened by 1/4 turn

7.5 Spare parts

It is possible to replace parts such as the gas tap, piezoelectric unit or ignition control unit (depending on the type of appliance), solenoid valve, level control unit or gas pipes in a quick and easy way.

To replace such parts, proceed as follows:

- **GAS TAP:** after disassembling the front panel, unscrew the gas connection screw couplings, remove the coupling, replace the faulty parts and install the new ones in sequence
- **THERMOCOUPLE:** unscrew the pilot burner coupling, unscrew the gas tap coupling in the same way and replace the element
- **SPARK PLUG:** unscrew the coupling, remove the damaged one and replace it.
- **SOLENOID:** Unscrew the couplings, remove the wiring connecting it to the level control unit and replace the coil
- **LEVEL CONTROL UNIT :** remove the wiring connecting it to the solenoid and sensor, unscrew the screws securing it to the base of the unit and replace it

**Caution****WHAT TO DO IN THE EVENT OF FAULTS:**

Close the gas connection cock and/or switch off the power using the up-line device. Notify customer service.

**Warning****MEASURES TO BE TAKEN IF THE APPLIANCE IS NOT TO BE USED FOR A LONG TIME:**

Close the gas cock and/or disconnect the power supply. Clean the system as specified above.

8 CLEANING

8.1 Routine cleaning

**Caution**

The use of flammable fluids to clean the appliance is forbidden

To ensure hygiene and the durability of the appliance, perform external cleaning on a regular basis, taking care not to damage the cables and the electrical connections. Before starting cleaning, disconnect the appliance from the power supply. Parts in steel can be washed with warm water and a neutral detergent: Rinse them thoroughly to eliminate all traces of detergent and then dry with a dry cloth. Do not use abrasive and corrosive detergents. Enamelled parts must be washed with soapy water. For appliances that included an oven, cleaning it is made easier by removing the support grid. Thorough, daily cleaning prevents faults and accumulated deposits of fat and/or food. The steels used in the manufacture of professional equipment are tried and tested materials of the highest quality. Thanks to their characteristics, they are ideal materials for use with food substances.

Consequently, when using stainless steel appliances, the following suggestions must be observed:

- Stainless steel surfaces must always be kept clean, also ensuring contact with the air. The lack of oxygen under layers of scale, starch, egg white or other deposits means that surfaces can be affected by corrosion
- Do not use products containing salt or sulphuric acid to remove scale. Suitable products are available commercially but a diluted solution of acetic acid can also be used
- To clean STAINLESS STEEL appliances, it is advisable to use detergents specifically formulated for this material. For "minor cleaning", a mild washing up liquid solution may also be used
- **Do not wash the appliance with jets of water under pressure**
- Avoid using detergents containing abrasive powders or bleaches of any kind
- Lockable stainless steel appliances, during periods of inactivity, must be left uncovered so that air can freely access internal metal surfaces
- Stainless steel must not remain in contact for long periods with concentrated acids or with aromatised concentrates such as salt solutions, mustard, spice mixtures or the like. At certain temperatures and concentrations, these substances can damage the passive layer. Contact surfaces must therefore be immediately rinsed with clean water and then dried
- It is inadvisable to use stainless steel pots exclusively to cook foods in salt water (pasta, rice, potatoes, etc.). From time to time, these pots must also be used to cook foods containing fats or vegetables. This helps to prevent damage caused by corrosion
- After cooking foods in salt water, rinse the tanks with fresh water since salt water residues from cooking form layers of highly concentrated saline solution that can cause spotting corrosion
- To prevent so-called secondary corrosion, prolonged contact of stainless steel with ferritic steels should be avoided
- Any secondary corrosion spots must be eliminated immediately
- Do not use sharp objects that may scratch stainless steel parts and consequently give rise to deterioration